



ADAPTALARM Can Only

Ref : 115-121-001

User Guide

efa France

Z.A. La Haute Limougière 3, rue Claude Chappe
F - 37230 Fondettes

Tel.: +33 (0) 2 47 61 78 50 // Fax: +33 (0) 2 47 61 78 51
E-Mail: efa@efa-france.com // web : www.efa-controls.com



efa Deutschland

Mollwitzstr. 2
14059 Berlin

Tel.: +49 (0)30 30 111 870 // Fax: +49 (0)30 30 111 877
e-mail: efa@efa-berlin.com // web : www.efa-industries.com

Contents

Contents	2
1 Characteristics.....	3
1.1 Dimensions.....	3
1.2 Operating characteristics	4
2 Installing the device.....	4
2.1 Fitting the Adaptalarm	4
2.2 Wiring up the adaptalarm	5
3 System operation	5
3.1 Sounds enabled on the CAN bus.....	5
3.1.1 Start/Stop read mode.....	6
3.1.2 Single read mode	6
3.2 Priority Principle	6
3.3 Day/Night Mode	7
3.4 Launching the Adaptalarm software.....	7
4 The Adaptalarm Software	8
4.1 CAN-bus configuration	8
4.2 Choosing the CAN sounds	9
4.2.1 Adding a sound	9
4.2.2 Saving a sound configuration.....	9
5 CAN Bus Communication	10
5.1 Frame to be transmitted to Adaptalarm.....	11
5.2 Frames to be emitted by the Adaptalarm	12
5.2.1 Acknowledgment Frame	12
5.2.2 Status Frame	12

1 Characteristics

1.1 Dimensions

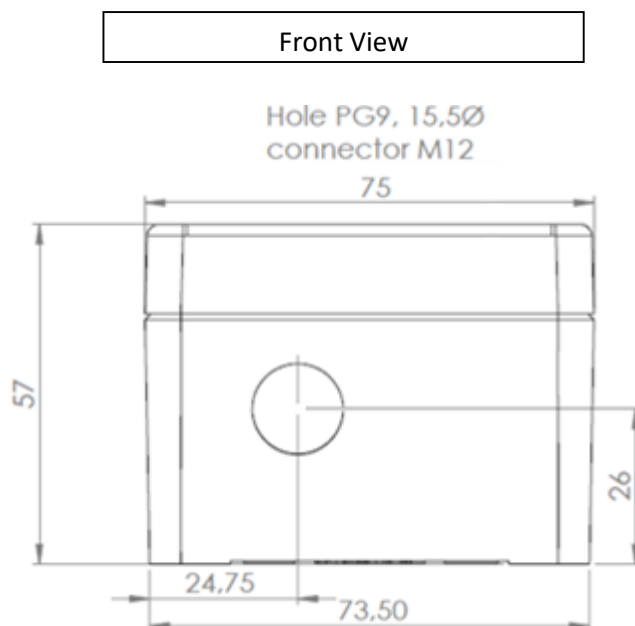
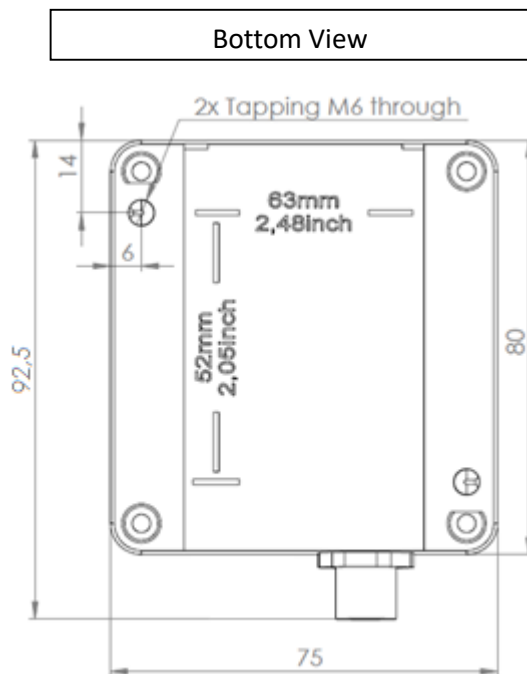

1.2 Operating characteristics

Supply voltage	9 à 32VDC
Nominal current	≈100mA
Operating temperature	-40 à 85°C
CAN Bus supported speed rates	125kb/s ; 250kb/s ; 500kb/s
Maximum sound power	95dB
Audio formats supported	.WAV (up to 48kHz), 16bits, Mono
Minimum sound duration	500ms
Maximum sound duration	Limited by the size of the memory (4GB)
Minimum interval between 2 CAN frame transmissions	100ms

2 Installing the device

In this chapter, we will be looking at how to fit your Adaptalarm to your system and how to wire it up.

2.1 Fitting the Adaptalarm

Adaptalarm can be rear-fitted using 2 holes with M6 threads;

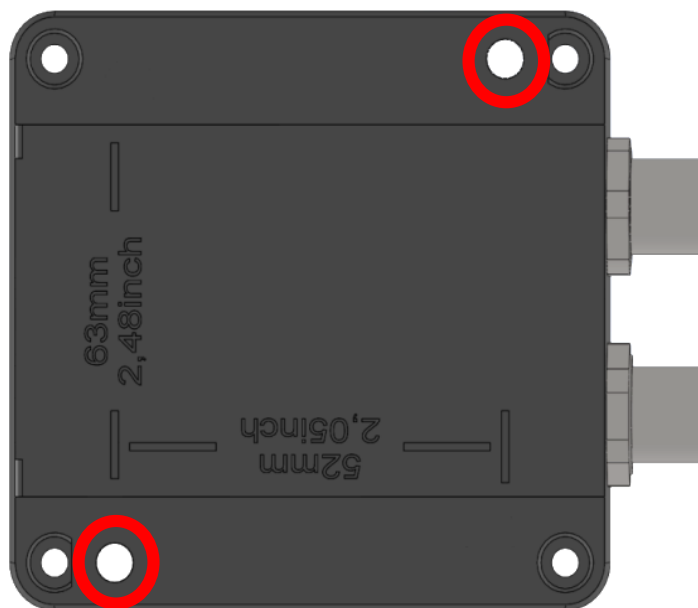

The distance between the two tapped holes is indicated on the housing (63mm and 52mm).

WARNING : The recommended tightening torque for the cover screws is 1.1 Nm.

2.2 Wiring up the adaptalarm

Adaptalarm CAN ONLY is equipped with one 5 pins M12 connector (waterproof once wired or protected by plastic cap included), used for current supply and CAN bus.



Pins are allocated as follows :

M12, 5 pins
1 – CAN S
2 – Vcc
3 – GND
4 – CAN H
5 – CAN L

Cables and accessories are also distributed by EFA France.

3 System operation

Adaptalarm Can Only includes a CAN Bus 2.0 A/B allowing it to manage sounds in different ways.

3.1 Sounds enabled on the CAN bus

The CAN Bus must be wired on pins 4 (CAN H) and 5 (CAN L) of the 5-pins connector. A CAN Shield (CAN S) is available on pin 1.

There are 2 read modes for playing CAN Sounds : « Start/Stop » and « Single Read ».

3.1.1 Start/Stop read mode

The sound requested via the CAN Bus is played in a loop when the Start/Stop bit is enabled, otherwise the sound is stopped

In start/stop mode, the volume of the sound can be modified at any time.

3.1.2 Single read mode

The sound requested via the CAN is played once in full when the Single read bit is enabled.

The sound can be stopped before it is finished by activating the requested sound Stop.

In single read mode, the volume has to be set in the single read CAN Frame and cannot be modified during the sound playing.

Tips & Tricks : If Start/Stop playback bit is activated, you can activate single playback to end the sound playing at its end.

3.2 Priority Principle

One of the main Adaptalarm operating principles, priority is used to classify the sounds according to their functional importance (by order of priority).

The purpose is to interrupt sounds while they are being read when another sound with a higher priority level needs to be played. When the sound with the higher priority is disabled, the other sound is re-enabled if it is still active.

Example: a sound simulating the noise of a vehicle operating (sound 4) is in the process of being read and another sound is enabled (sound 3) with a higher priority to warn of a hazard. The sound simulating the noise a vehicle makes is therefore interrupted by the sound with the higher priority which is then enabled. Once the sound warning of the hazard has finished playing, the sound simulating the noise a vehicle makes is re-enabled.

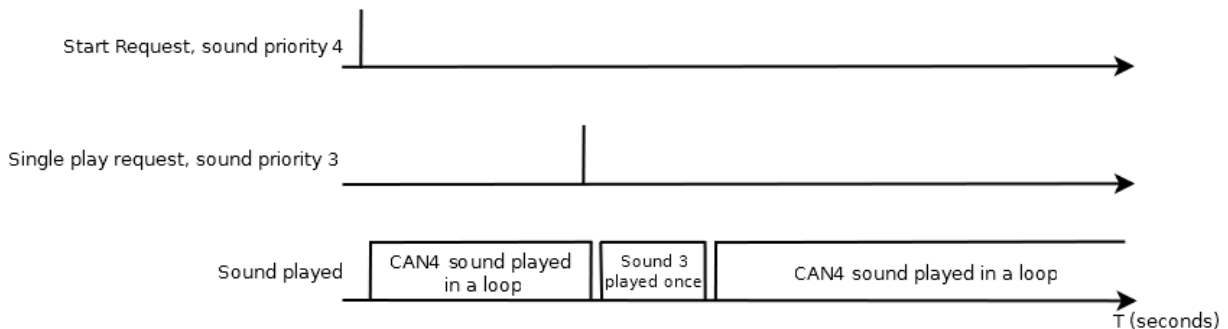

The software interface is used to choose the priority values.

Priority Principle can be disabled via the Priority bit. The sound without priority can then interrupt any type of sound to be played and can be interrupt by any sound request.

3.3 Day/Night Mode

This mode reduces the sound power of the played sounds by 25%.

Night mode is active if Day / Night mode bit is activated otherwise Day mode is activated (no noise reduction).

3.4 Launching the Adaptalarm software

It is possible to add your own sounds. To do this, the Adaptalarm includes a software which allows to integrate and to parameterize the priority of each new sound. The software also allows configuration of the CAN bus.

To access the software, follow these steps:

1. Make sure that the Adaptalarm is not powered;
2. Remove the Adaptalarm cover;
3. Push the micro-SD card out of the connector;
4. Connect the micro-SD card to a computer (use a USB-micro-SD adapter if necessary);
5. Browse the micro-SD card from your computer and double-click the "Adaptalarm" folder;
6. Double-click the "Adaptalarm_VXX.exe" file (XX is the version of the software).

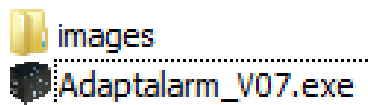

After double-clicking on the file, a window asks you to choose the language of the software, once the language is chosen, another window appears to choose the version of the Adaptalarm, choose "CWS-C1-A0-D0-_".

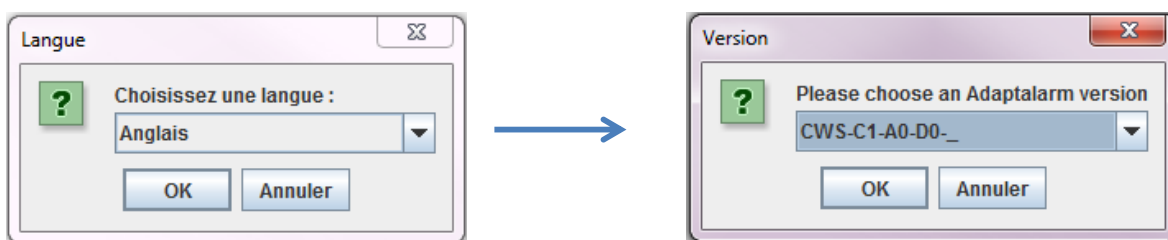

4 The Adaptalarm Software

Once opening « Adaptalarm.exe » file and after selecting the language and version of Adaptalarm, the following window should appear (if not, the software may propose you to update the JAVA environment. A link to the Internet will allow you to then perform this update) :

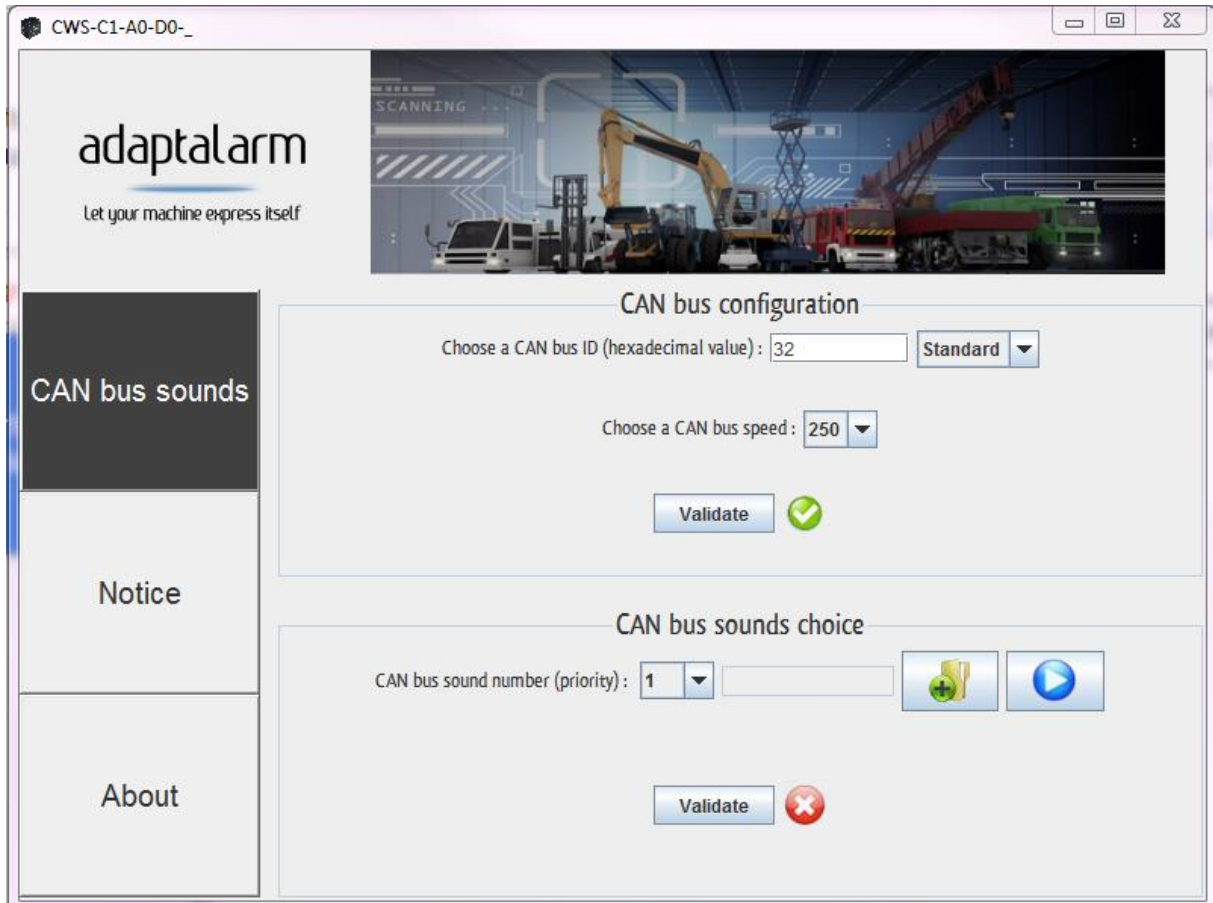

The software consists of three tabs (located on the left) and a settings area (in the center). "CAN Sounds" can be used to set the CAN bus (format, ID and speed) and CAN sounds.

The other navigation buttons allow to display this same user guide ("Notice") as well as additional information ("About").

4.1 CAN-bus configuration

The software offers the possibility to choose the Adaptalarm ID on the CAN bus and can adapt to 3 different CAN communication speeds.

The identifier must be specified in hexadecimal, in standard (11-bit) or extended (29-bit) format.

The communication speeds available are 125kb / s, 250kb / s and 500kb / s.

By default, the identifier is 0x32 in standard format at 250kb / s.

An indicator next to the "Confirm" button informs you whether the parameters displayed are the parameters saved via the "Confirm" button.

WARNING : Make sure to choose an identifier whose values + 1 and + 2 are available (see Chapter 5). For example, if the identifier is 0x32; make sure that the identifiers 0x33 and 0x34 are available on the CAN bus.

4.2 Choosing the CAN sounds

You can change the priority of the sound by clicking in the box indicating the sound number.

If a sound is already present, the name of this sound will appear as "SONX" where X is the priority of the sound. It is then possible to play the sound by clicking on the playback button (in blue).

It is possible to add as many CAN sounds as there are available priorities (knowing that there can not be 2 sounds with the same priority), or 254 sounds.

4.2.1 Adding a sound

You can choose to embed a new sound (in .WAV format), or replace the existing sound by clicking the folder icon next to the play button.

4.2.2 Saving a sound configuration

Once the sound is selected and adjusted, you can confirm/save the selected sound by clicking on "Validate".

A message may occur after validation if the priority of the sound is already taken by another sound.

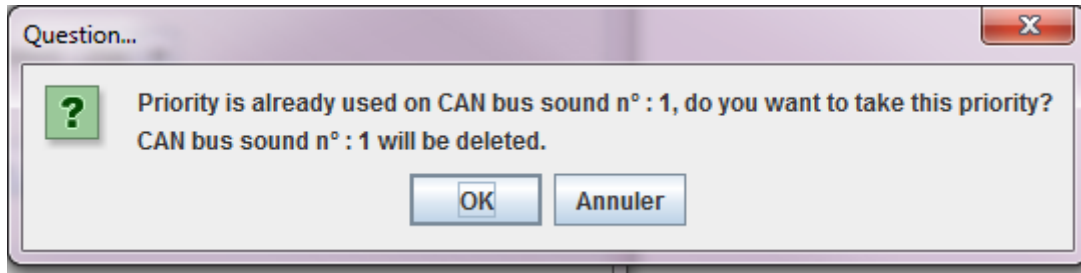

You can then validate with "OK", the sound then takes precedence of the other sound and it will be deleted, either click on "Cancel" and nothing will be modified.

Tips & Tricks : This method can be used to delete a CAN sound that you are no longer using.

5 CAN Bus Communication

The Adaptalarm is controlled via frame sending on its CAN bus. It is possible to choose the bus communication speed as well as the Adaptalarm identifier on the bus.

When a CAN frame is sent to the Adaptalarm, the Adaptalarm returns an acknowledgment frame containing the information you have just sent.

The acknowledgment frame sent by the Adaptalarm has an ID value equal to the value of the configured ID + 1. By default, it is $0x32 + 1 = 0x33$.

When the Adaptalarm plays a sound or stops playing a sound, it will also output a status frame indicating the sound played or stopped and its volume.

The frame indicating whether a sound is played has an ID value equal to the value of the configured ID + 2. By default, it is $0x32 + 2 = 0x34$.

5.1 Frame to be transmitted to Adaptalarm

FUNCTION	BYTE	BITS	USE
Day/Night Mode	0	0 - 1	= 0 or = 1 or = 3 : day mode (no sound reduction) = 2 : night mode activated
Start/Stop Playback		4	= 0 : cancels the request or stops looping the selected sound = 1 : requires looping of the selected sound
Stop All		5	= 0 : no effect = 1 : stops the played sound and cancels playback requests
Priority		6	= 0 : the priority principle is activated on the selected sound = 1 : the selected sound is played without a priority principle
Single Playback		7	= 0 : cancels the request or stops single playback of the selected sound = 1 : request to play the selected sound
Volume	1	-	Sound volume from 1 to 100
Sound Selection	2	-	Sound number from 1 to 254

The identifier (ID) is the value of the configured identifier.

IMPORTANT NOTE: If both the Start / Stop Play bit and the Single Play bit are enabled, the playback request will be a single playback.

EXAMPLE: If the following frame is sent to Adaptalarm and the address value is set to 0x32:

ID Hexadecimal value	Data		
	Byte 0	Byte 1	Byte 3
0x32	0x80	0x30	0x01

Then the sound 1 (priority 1) will be played in single playback (0x80) with the sound volume at 48% (0x30) of the maximum volume.

5.2 Frames to be emitted by the Adaptalarm

The Adaptalarm returns two different types of frames.

5.2.1 Acknowledgment Frame

The identifier of this frame is worth the value of the configured identifier + 1.

The acknowledgment frame returns the information received by the Adaptalarm on the CAN bus. This frame makes it possible to ensure that a request is taken into account.

EXAMPLE: Starting from the previous example, the Adaptalarm will issue the following frame:

ID Hexadecimal value	Data		
	Octet 0	Octet 1	Octet 3
0x33	0x80	0x30	0x01

5.2.2 Status Frame

The identifier of this frame is worth the value of the configured identifier + 2.

The status frame indicates the real-time activity of the Adaptalarm.

FUNCTION	BYTE	BITS	USE
Sound Status	0	0	= 0 : playback stopped = 1 : playing the current sound
Volume	1	-	Sound volume when started / ended from 1 to 100
Sound playback	2	-	Sound number start / end from 1 to 254

EXAMPLE : Starting from the previous example, once the sound is played, the Adaptalarm will issue the following frame:

ID Hexadecimal value	Data		
	Byte 0	Byte 1	Byte 3
0x34	0x01	0x30	0x01